

# GL2200

The **GL2200** is the definitive universal mixing desk, the essential piece of your professional PA system of hire stock, bridging the gap between small and large format desks and providing the perfect balance of features and functionality to be used for everyday mixing duties in any environment.

This console is the world's leading affordable, small format, 4 group, 6 aux, dual function live mixer with a well thought-out feature set, great sound and rugged individual PCB build, which outlasts and outperforms the competition.

Trust **ALLEN&HEATH** to give you the best.



## TOP FEATURES

### Dual Functionality

The mark of any successful product is its ability to satisfy the expectations of its users, and because of the flexibility of the FOH Monitor mode switching the **GL2200** has established itself as a leader.

In FOH mode, the 4 groups with inserts, long throw faders, and XLR outputs, can be routed and panned to the LR mix for sub-mixing. The main LR mix has inserts, separate left and right faders, and XLR outputs, to feed the main speaker system. EQ and signal processing can easily be inserted on group and main outputs.

### Monitor

In Monitor mode, the aux mixes are routed to the group and LR faders, inserts, and XLR output. The AFL and PFL system is switched to the Mono output to provide an engineers 'wedge' output. In essence, it's a perfect 6-mix monitor console with additional outputs available from the group busses via the aux master controls.

To allow maximum flexibility, it is possible to operate the console in dual mode where some aux mixes can be used as monitors and some sub-grouping can be used along with the main LR outputs. This allows the engineer to run FOH sound and Monitor mixes from the same console.

### Stereo Channels

The **GL2200** has 2 fully featured stereo channels each including a mic preamp and stereo line input. The stereo input can be routed directly to LR if needed, enabling the channel to be used as a mic channel. In addition, 2 stereo returns are provided for FX and other inputs, and include EQ, aux sends, and routing to the groups, allowing FX to be returned to a subgroup when the balance between 'wet' and 'dry' needs to be maintained. The mic input on one stereo channel can be switched to become the talkback source.

### Engineer's Toolbox

The clearly laid out master section provides all the essential control and monitoring facilities you need. Metering is provided for the groups and LR outputs, and two 12 segment bar meters are provided for monitoring which complement the input channel meters. The extensive PFL/AFL system allows signal quality checking and metering. The signal generator and Talkback section allows the engineer to check outputs using 1kHz tone or pink noise, or talk to the aux, group and LR, giving full communication. The 2-track send and return section provides for simple recording and music playback. Aux masters with AFL, Mono output with

wedge mode, headphone monitor level control, and a lamp socket, complete the line-up. To power the console, a universal input high-efficiency PSU is built into the console and, for that extra peace of mind, a built-in combiner allows an external backup PSU to be connected.

### Sound Quality

As you would expect from a leading British console manufacturer, the precise 'British' EQ and high quality preamp, provide the ideal ingredients for a quality sound system. The direct outputs from each channel combine with the groups to ensure this console is equally well suited to recording applications.

## FEATURES at a glance

### DUAL FUNCTIONALITY

Mode switching front of house and/or stage monitor mixing, offering up to 6 monitor sends on 100mm faders

### FRAMES

12, 16, 24 or 32 channels, including 2 stereo, with 100mm faders and inserts

### 2 STEREO CHANNELS

4 band EQ, full routing and mute. Mono mic and stereo line inputs

### 2 STEREO RETURNS

with 60mm faders, EQ and aux sends

### 4 AUDIO GROUPS

panned subgrouping to LR

### 6 AUXILIARY SENDS

1-4 and 5,6 switchable pre/post. Can reverse with fader masters for monitor mode

### 4 BAND EQ

There are separate controls for sweep on the mid bands allowing pin point enhancement at key frequencies

### FILTER

Switchable HPF at 100Hz

### PHANTOM POWER

switchable, on each channel

### CHANNEL METERS

4 LED metering next to the faders provide instant indication of all signals

### TALKBACK

to the groups, LR and pairs of auxes

### DIRECT OUTPUTS

every mono channel has a direct output on TRS for recording and dedicated FX

### ENGINEER'S TOOLBOX

Comprehensive AFL/PFL monitoring, input, output and master metering, headphone socket and oscillator/pink noise generator available for setup

### LAMP SOCKET

BNC connector located on master section

### EXPANSION

Sys-Link V1 option allows connection to other consoles fitted with Sys-Link 1

### PSU

built-in power supply with combiner socket

### CONFIGURATION OPTIONS

individual aux sends as pre/post fader and pre EQ. Direct out can be configured pre-fade, pre-fade aux can be isolated from channel mute. Internal solder link options to configure pre-fade auxes, and direct outputs. Electronic balance option for auxes



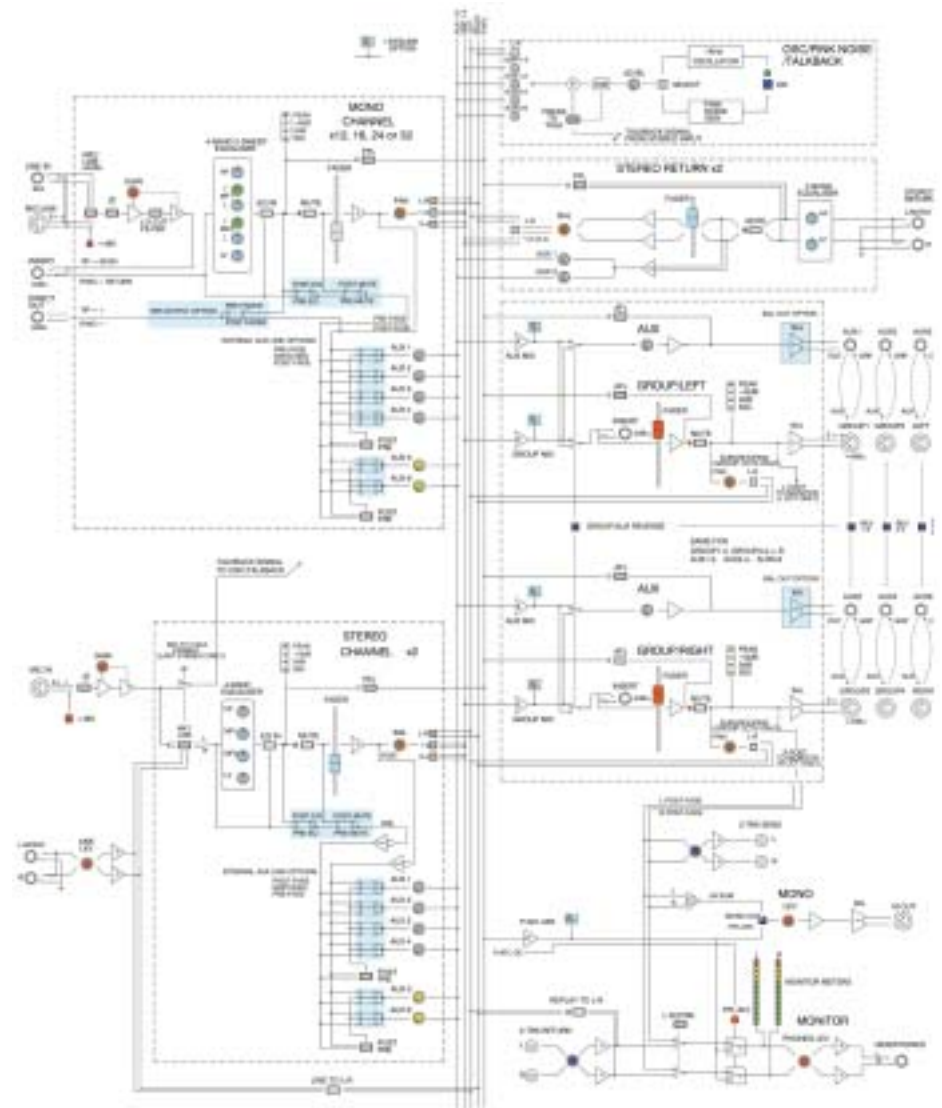

**GL2200**  
System Block Diagram